

NOTES:

1. MATERIAL: 316L STAINLESS STEEL, NICKEL BRAZED.
2. ALL EXTERNAL SURFACES SATIN FINISH.
3. MAXIMUM OPERATING CONDITIONS:
 - PRESSURE: TUBESIDE - 1,500 psi (103 bar)
SHELLSIDE - 1,000 psi (69 bar)
 - TEMPERATURE: 800°F (425°F)
 - PRESSURE FOR STEAM SERVICE: 125 psi (8.6 bar)
 - FLUID TEMPERATURE DIFFERENCE:
(T_{HOT})_{AVE} - (T_{COLD})_{AVE} < 125°F (70°C)

- #	TUBE COUNT	TUBE LENGTH		DIM A		DIM B		WEIGHT EMPTY		TRANSFER AREA	
		in	mm	in	mm	in	mm	lb	kg	ft ²	m ²
- 01	37	8.00	203	11.34	288	6.81	173	1.03	0.47	0.58	0.05
- 02		12.00	305	15.34	390	10.81	275	1.25	0.57	0.89	0.08
- 03		16.00	406	19.34	491	14.81	376	1.45	0.66	1.19	0.11
- 04	19	8.00	203	11.34	288	6.81	173	1.00	0.45	0.40	0.04
- 05		12.00	305	15.34	390	10.81	275	1.19	0.54	0.61	0.06
- 06		16.00	406	19.34	491	14.81	376	1.39	0.63	0.81	0.08
- 08	37	20.00	508	23.34	593	18.81	478	2.09	0.95	1.49	0.14
- 09		25.00	635	28.34	720	23.81	605	2.46	1.12	1.87	0.17
- 10		30.00	762	33.34	847	28.81	732	2.83	1.28	2.25	0.21
- 11	19	20.00	508	23.34	593	18.81	478	2.02	0.92	1.02	0.09
- 12		25.00	635	28.34	720	23.81	605	2.37	1.08	1.28	0.12
- 13		30.00	762	33.34	847	28.81	732	2.72	1.23	1.54	0.14

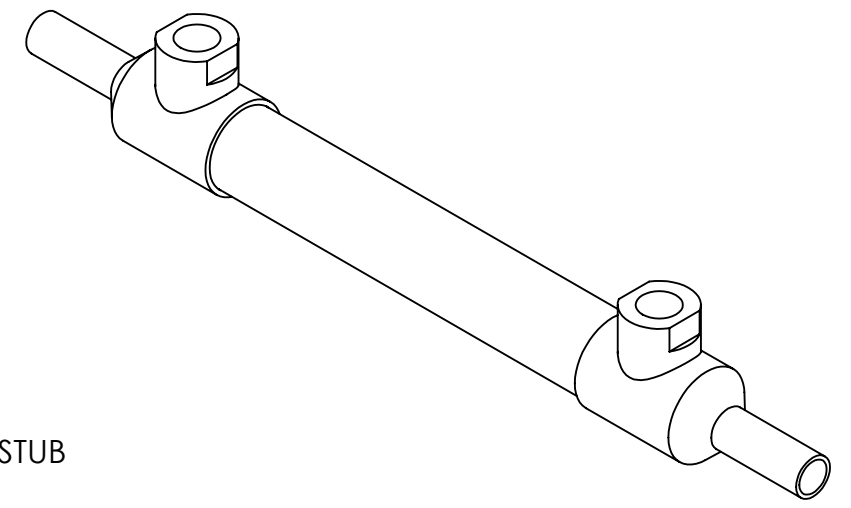
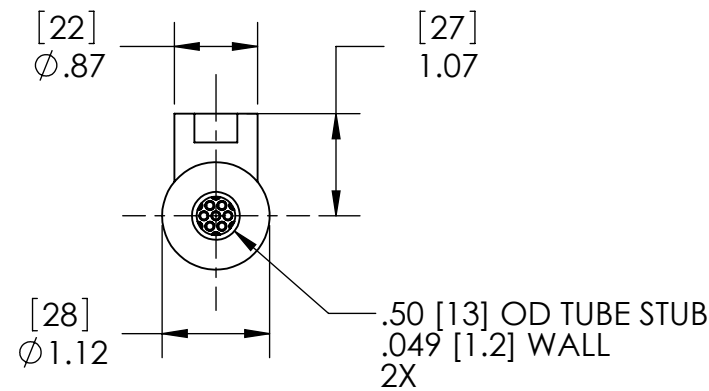
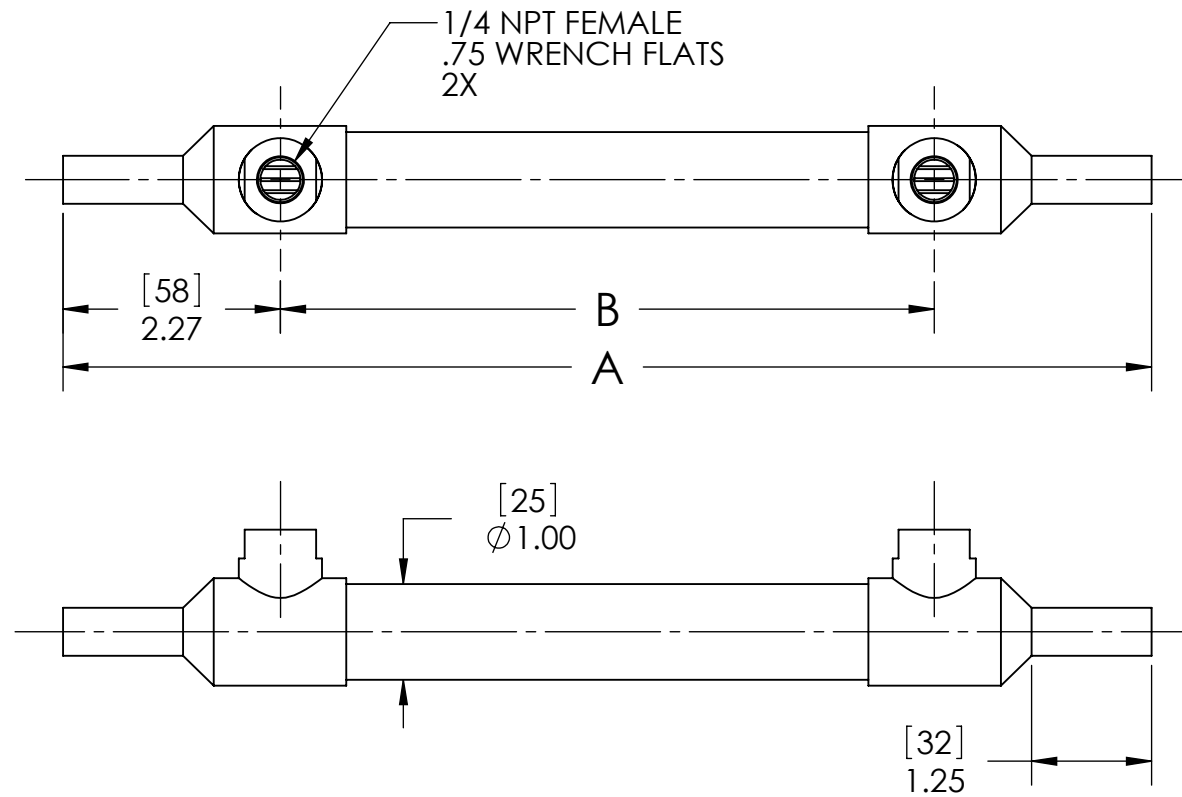

ALSO AVAILABLE

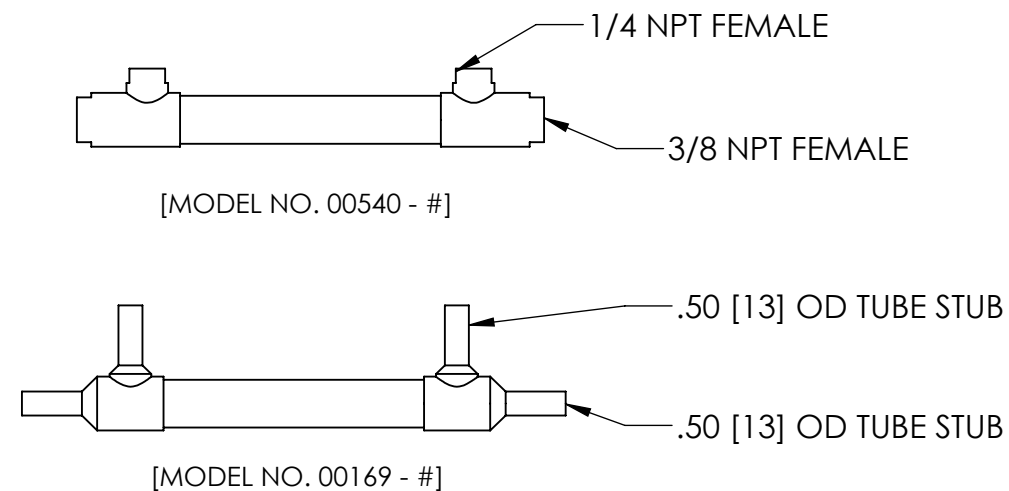

ALL DIMENSIONS ARE IN INCHES [mm]

PROPRIETARY AND CONFIDENTIAL
 THE INFORMATION CONTAINED IN THIS DOCUMENT IS THE SOLE PROPERTY OF EXERGY, LLC. ANY REPRODUCTION, DISCLOSURE, OR USE, IN PART OR AS A WHOLE, WITHOUT THE WRITTEN PERMISSION OF EXERGY, LLC IS PROHIBITED.

PRODUCT SPECIFICATIONS SUBJECT TO CHANGE WITHOUT NOTICE. MANUFACTURER ASSUMES NO LIABILITY FOR MISUSE OR ABUSE OF PRODUCT. SPECIFIC WARRANTY INFORMATION IS AVAILABLE UPON REQUEST.

THIRD ANGLE PROJECTION

EXERGY HEAT TRANSFER SOLUTIONS
 320 ENDO BLVD. GARDEN CITY, NY 11530
 USA (516)832-9300 www.exergyllc.com

**SHELL & TUBE HEAT EXCHANGER
 23 SERIES
 TUBE SIDE TUBE STUB**

MODEL NO. **00415 - #**

DATE 9/19/2014 SCALE 1:2 SHEET 1 OF 1

MODEL NO. 00415 - #