

NOTES:

- MATERIAL: 316L STAINLESS STEEL.
 - INNER TUBE: .750 OD X .065 WALL.
 - OUTER TUBE: 1.250 OD X .065 WALL.
- SEE CHART FOR MAXIMUM PRESSURE AND TEMPERATURES. SANITARY CLAMPS MAY LIMIT MAXIMUM PRESSURE. GASKET MAY LIMIT MAXIMUM TEMPERATURE. CONSULT THE MANUFACTURER'S LITERATURE.
- FULLY DRAINABLE ON INNER TUBE SIDE WHEN MOUNTED WITH COIL AXIS IN VERTICAL ORIENTATION.
- MATERIAL AND PROCESS CERTIFICATIONS PROVIDED.

- #	EP	WEIGHT EMPTY		TRANSFER AREA	
		lb	kg	ft ²	m ²
- 01	•	32	14.5	3.7	.34
- 02					

Maximum Temperature and Pressure for All Models

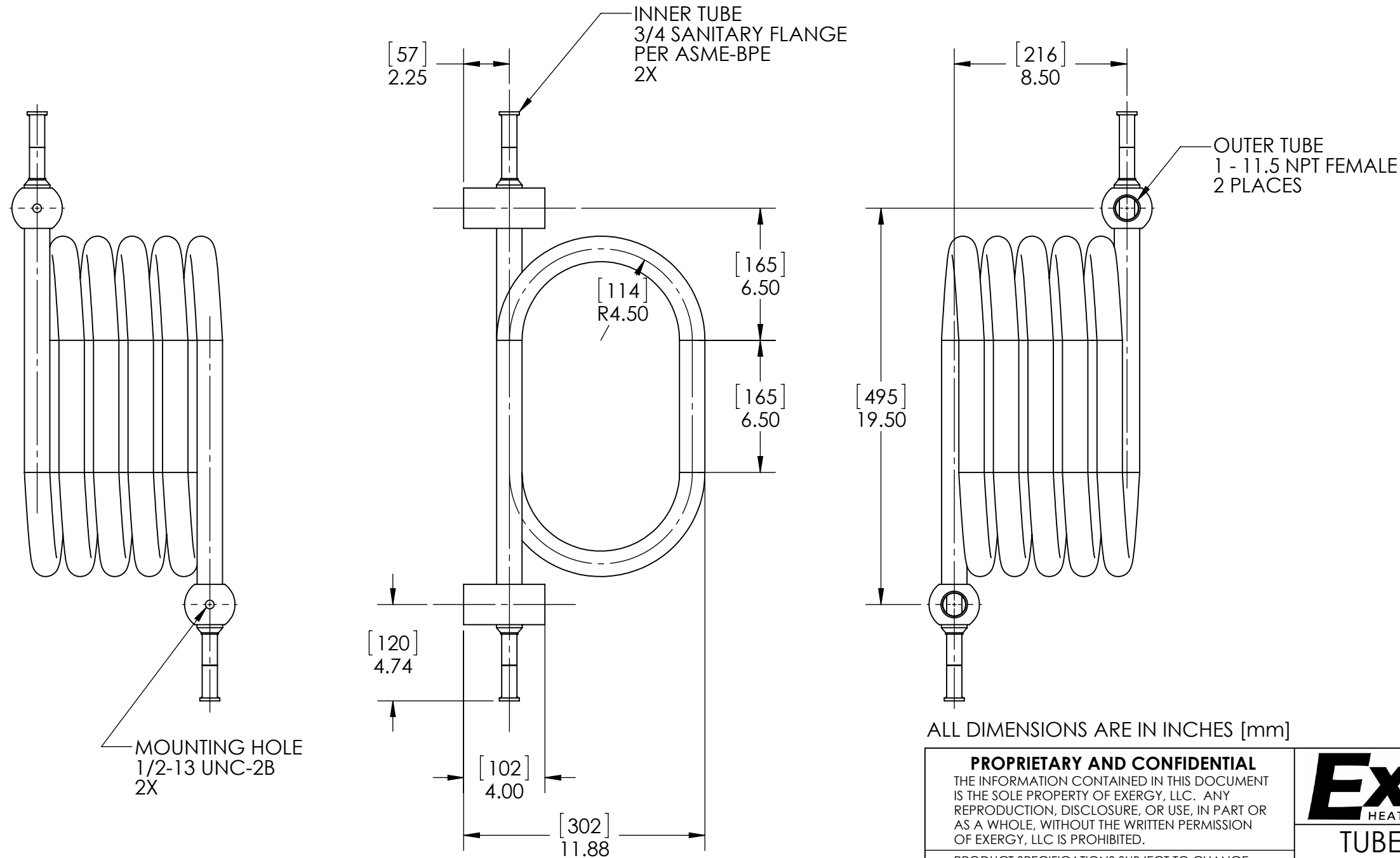
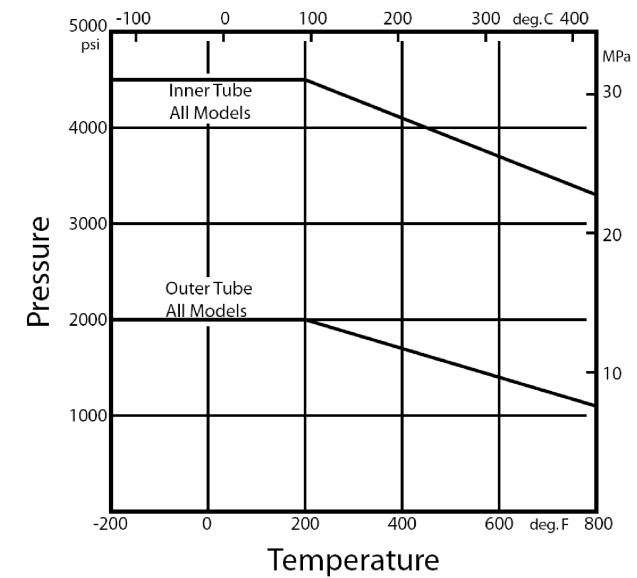

ALL DIMENSIONS ARE IN INCHES [mm]

PROPRIETARY AND CONFIDENTIAL
 THE INFORMATION CONTAINED IN THIS DOCUMENT IS THE SOLE PROPERTY OF EXERGY, LLC. ANY REPRODUCTION, DISCLOSURE, OR USE, IN PART OR AS A WHOLE, WITHOUT THE WRITTEN PERMISSION OF EXERGY, LLC IS PROHIBITED.

PRODUCT SPECIFICATIONS SUBJECT TO CHANGE WITHOUT NOTICE. MANUFACTURER ASSUMES NO LIABILITY FOR MISUSE OR ABUSE OF PRODUCT. SPECIFIC WARRANTY INFORMATION IS AVAILABLE UPON REQUEST.

THIRD ANGLE PROJECTION

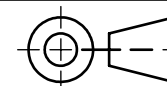

EXERGY
HEAT TRANSFER SOLUTIONS
 320 ENDO BLVD.
 GARDEN CITY, NY 11530
 USA (516)832-9300
 www.exergyllc.com

TUBE IN TUBE HEAT EXCHANGER
 1.25 OUTER TUBE
 SANITARY FLANGE, INNER TUBE

MODEL NO. 02191 - #
 DATE 9/25/2014 SCALE 1:6 SHEET 1 OF 1

MODEL NO.

02191 - #