

NOTES:

- MATERIAL: 316L STAINLESS STEEL.
 - INNER TUBE: .500 OD X .065 WALL.
 - OUTER TUBE: 1.000 OD X .065 WALL.
- SEE CHART FOR MAXIMUM PRESSURE AND TEMPERATURES. SANITARY CLAMPS MAY LIMIT MAXIMUM PRESSURE. GASKET MAY LIMIT MAXIMUM TEMPERATURE. CONSULT THE MANUFACTURER'S LITERATURE.
- FULLY DRAINABLE ON INNER TUBE SIDE WHEN MOUNTED WITH COIL AXIS IN VERTICAL ORIENTATION.
- MATERIAL AND PROCESS CERTIFICATIONS PROVIDED.

-#	# OF COIL	EP	WEIGHT EMPTY		TRANSFER AREA		ORIENTATION	SHEET
			lb	kg	ft ²	m ²		
-01	9	●	22.9	10.4	2.5	.23	RIGHT HAND	1
-02			22.9	10.4	2.5	.23	RIGHT HAND	1
-03		●	22.9	10.4	2.5	.23	RIGHT HAND	1
-04	9	●	22.9	10.4	2.5	.23	LEFT HAND	2
-05			22.9	10.4	2.5	.23	LEFT HAND	2

RIGHT HAND CONFIGURATION

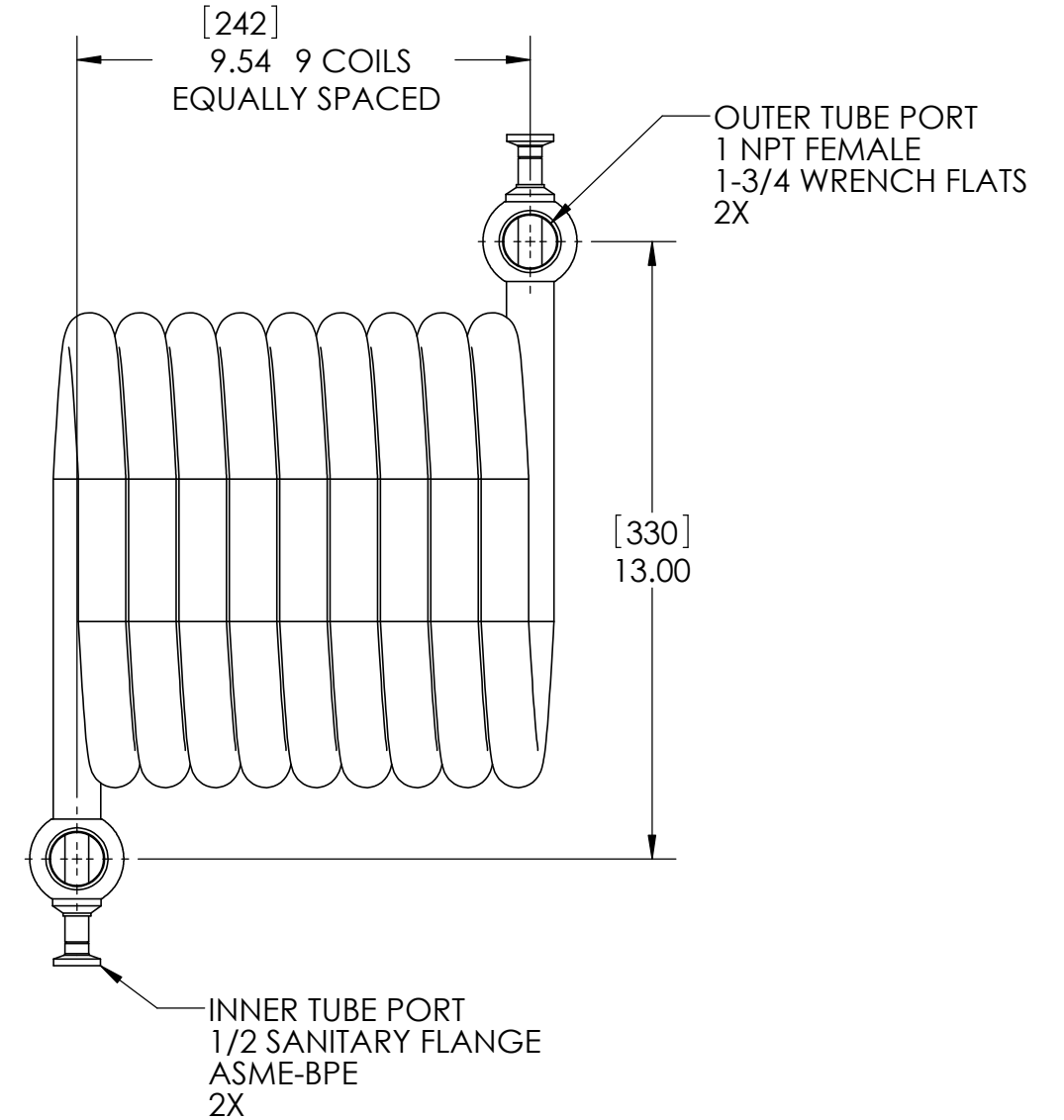
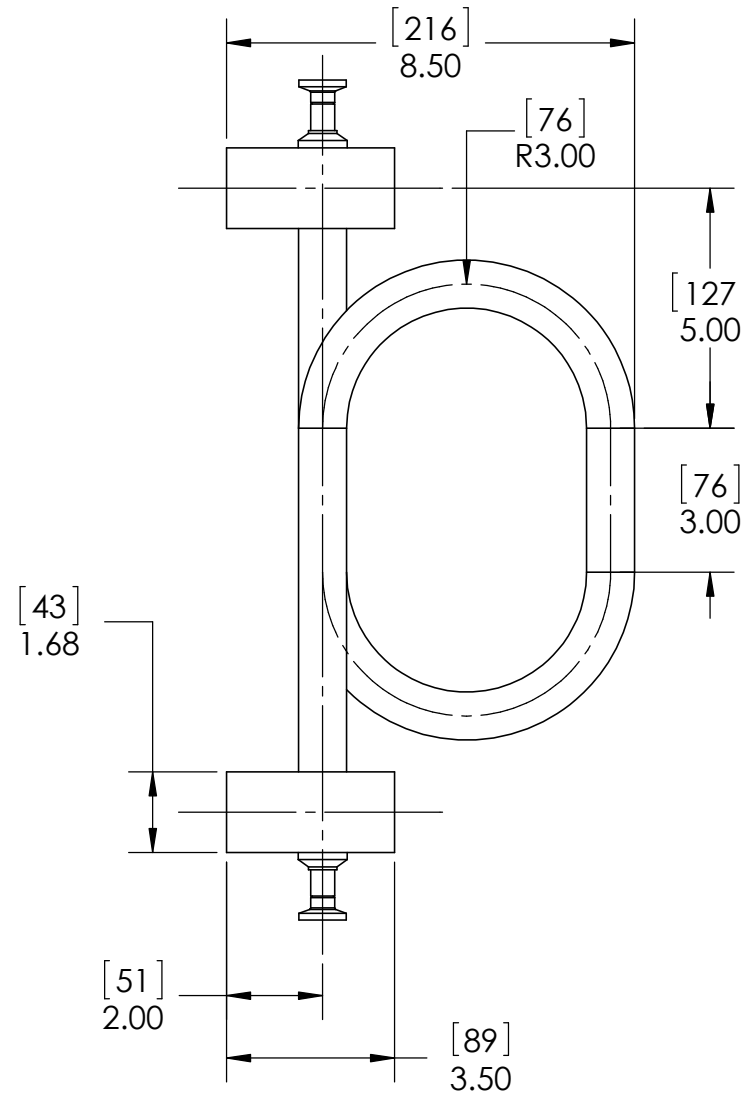
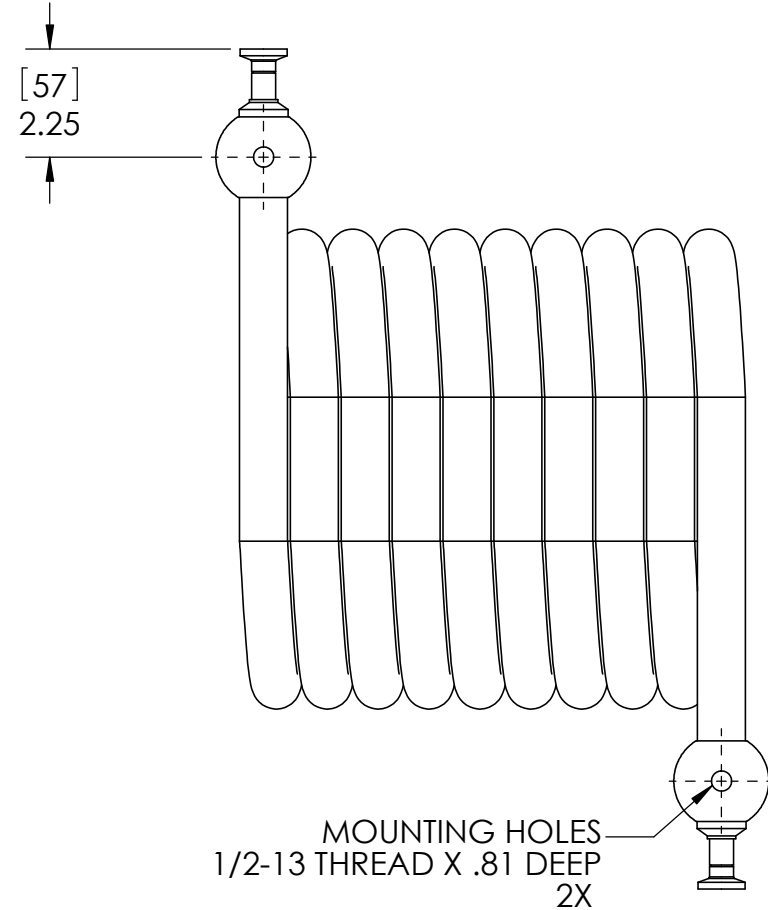

ALL DIMENSIONS ARE IN INCHES [mm]

PROPRIETARY AND CONFIDENTIAL
THE INFORMATION CONTAINED IN THIS DOCUMENT IS THE SOLE PROPERTY OF EXERGY, LLC. ANY REPRODUCTION, DISCLOSURE, OR USE, IN PART OR AS A WHOLE, WITHOUT THE WRITTEN PERMISSION OF EXERGY, LLC IS PROHIBITED.

PRODUCT SPECIFICATIONS SUBJECT TO CHANGE WITHOUT NOTICE. MANUFACTURER ASSUMES NO LIABILITY FOR MISUSE OR ABUSE OF PRODUCT. SPECIFIC WARRANTY INFORMATION IS AVAILABLE UPON REQUEST.

THIRD ANGLE PROJECTION

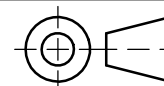

EXERGY HEAT TRANSFER SOLUTIONS
320 ENDO BLVD.
GARDEN CITY, NY 11530
USA (516)832-9300
www.exergyllc.com

TUBE IN TUBE HEAT EXCHANGER
1 OUTER TUBE X 1/2 INNER TUBE
SANITARY FLANGES

MODEL NO. 00644 - #
DATE 12/9/2014 SCALE 1:4 SHEET 1 OF 2

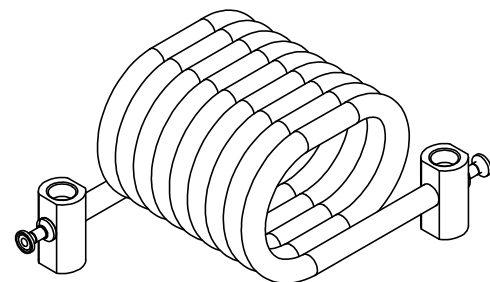
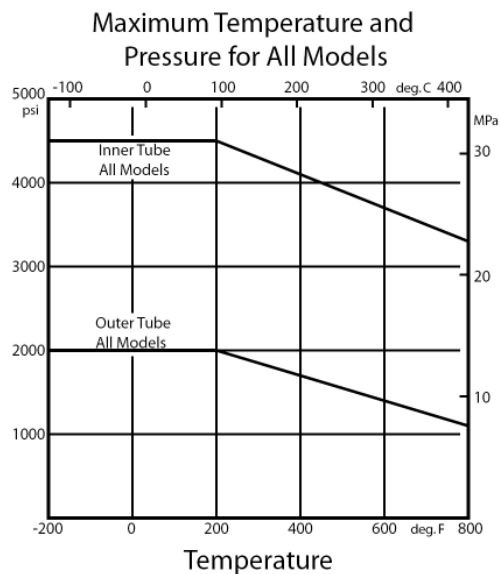

MODEL NO. 00644 - #

NOTES:

- MATERIAL: 316L STAINLESS STEEL.
 - INNER TUBE: .500 OD X .065 WALL.
 - OUTER TUBE: 1.000 OD X .065 WALL.
- SEE CHART FOR MAXIMUM PRESSURE AND TEMPERATURES. SANITARY CLAMPS MAY LIMIT MAXIMUM PRESSURE. GASKET MAY LIMIT MAXIMUM TEMPERATURE. CONSULT THE MANUFACTURER'S LITERATURE.
- FULLY DRAINABLE ON INNER TUBE SIDE WHEN MOUNTED WITH COIL AXIS IN VERTICAL ORIENTATION.
- MATERIAL AND PROCESS CERTIFICATIONS PROVIDED.

-#	# OF COIL	EP	WEIGHT EMPTY		TRANSFER AREA		ORIENTATION	SHEET
			lb	kg	ft ²	m ²		
-01	9	●	22.9	10.4	2.5	.23	RIGHT HAND	1
-02			22.9	10.4	2.5	.23	RIGHT HAND	1
-03		●	22.9	10.4	2.5	.23	RIGHT HAND	1
-04	9	●	22.9	10.4	2.5	.23	LEFT HAND	2
-05			22.9	10.4	2.5	.23	LEFT HAND	2

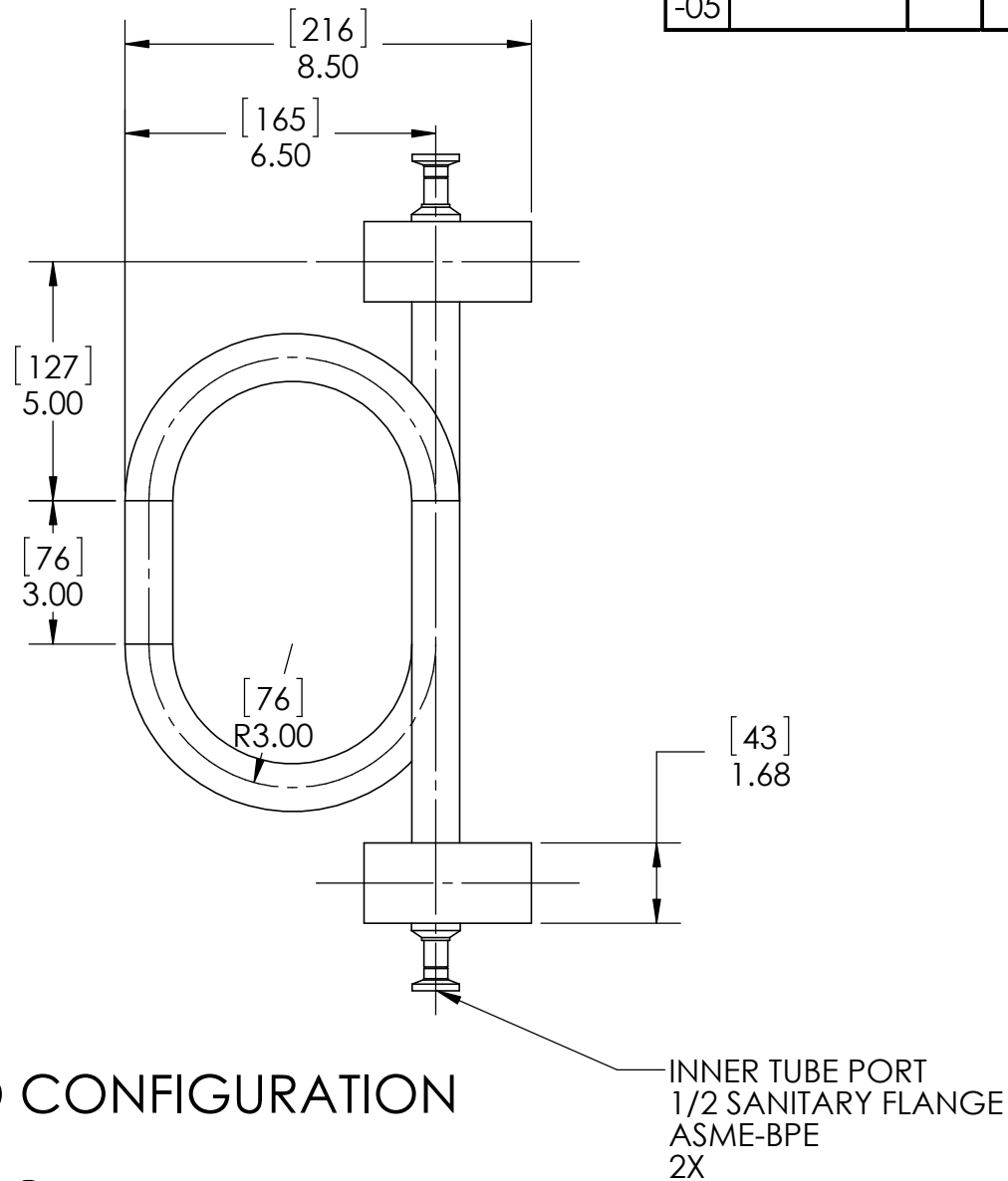
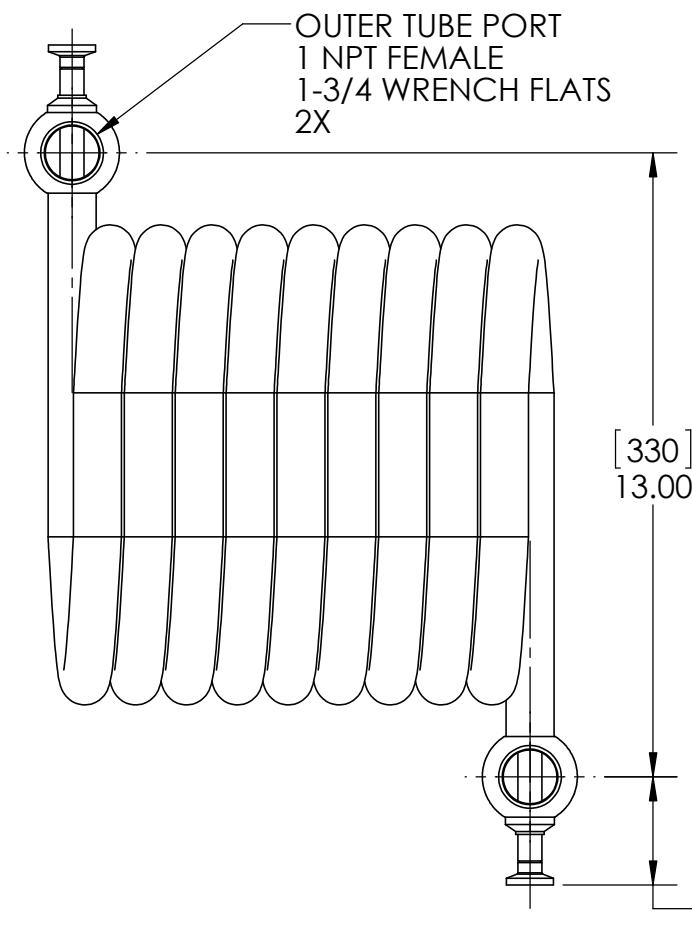

LEFT HAND CONFIGURATION

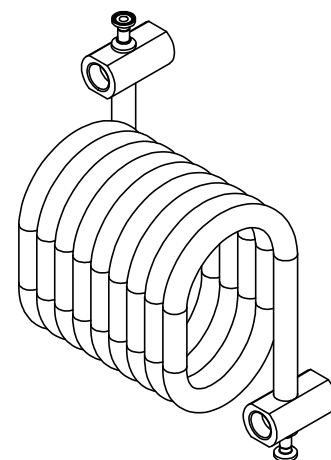
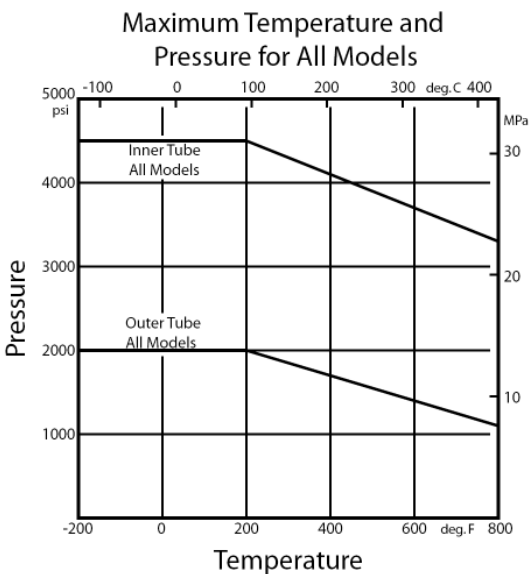
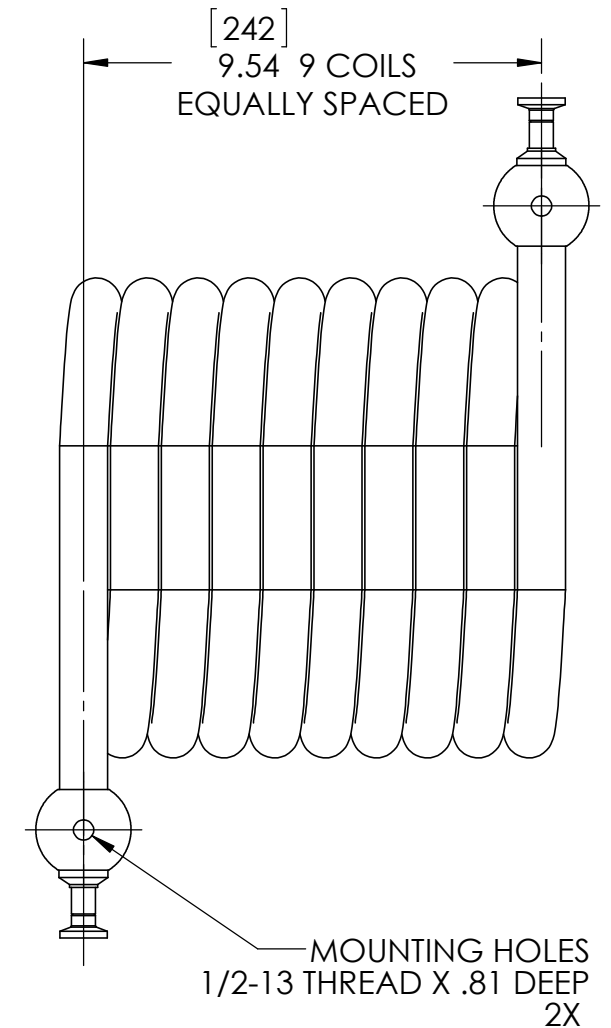

ALL DIMENSIONS ARE IN INCHES [mm]

PROPRIETARY AND CONFIDENTIAL
 THE INFORMATION CONTAINED IN THIS DOCUMENT IS THE SOLE PROPERTY OF EXERGY, LLC. ANY REPRODUCTION, DISCLOSURE, OR USE, IN PART OR AS A WHOLE, WITHOUT THE WRITTEN PERMISSION OF EXERGY, LLC IS PROHIBITED.

PRODUCT SPECIFICATIONS SUBJECT TO CHANGE WITHOUT NOTICE. MANUFACTURER ASSUMES NO LIABILITY FOR MISUSE OR ABUSE OF PRODUCT. SPECIFIC WARRANTY INFORMATION IS AVAILABLE UPON REQUEST.

THIRD ANGLE PROJECTION

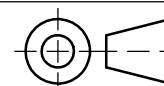

EXERGY HEAT TRANSFER SOLUTIONS
 320 ENDO BLVD. GARDEN CITY, NY 11530
 USA (516)832-9300 www.exergyllc.com

TUBE IN TUBE HEAT EXCHANGER
 1 OUTER TUBE X 1/2 INNER TUBE
 SANITARY FLANGES

MODEL NO. 00644 - #
 DATE 12/9/2014 SCALE 1:4 SHEET 2 OF 2

MODEL NO.

00644 - #